



## Legal and Vesting Product Cover Sheet

### ORDER INFORMATION

FILE/ORDER NUMBER:	LL-HCBAT-00922	PRODUCT NAME:	LEGAL AND VESTING
BORROWER NAME(S):	MICHAEL DIENER AND MARIA DIENER		
PROPERTY ADDRESS:	302 WESTON ROAD, BROWNSBURG, IN 46112		
CITY, STATE AND COUNTY:	BROWNSBURG, INDIANA (IN), HENDRICKS		

### SEARCH INFORMATION

SEARCH DATE:	09/30/2024	EFFECTIVE DATE:	09/27/2024
NAME(S) SEARCHED:	MICHAEL DIENER AND MARIA DIENER		
ADDRESS/PARCEL SEARCHED:	302 WESTON ROAD, BROWNSBURG, IN 46112 / 32-07-15-258-009.000-016		

### ASSESSMENT INFORMATION

COMMENTS:	
-----------	--

### CURRENT OWNER VESTING

MICHAEL F. DIENER	
COMMENTS:	

### VESTING DEED

DEED TYPE:	QUITCLAIM DEED	GRANTOR:	MARIA J. DIENER
DATED DATE:	02/16/2024	GRANTEE:	MICHAEL F. DIENER
BOOK/PAGE:	N/A	RECORDED DATE:	02/20/2024
INSTRUMENT NO:	202402934		
COMMENTS:			

### FOR PREAMBLE

CITY/TOWNSHIP/PARISH:	TOWN OF BROWNSBURG
-----------------------	--------------------

### ADDITIONAL NOTES

TRANSFER ON DEATH DEED IS RECORDED ON 05/06/2022 IN INSTRUMENT NO. 202211025.

QUITCLAIM DEED IS RECORDED ON 05/04/2022 IN INSTRUMENT NO. 202210751.

WARRANTY DEED IS RECORDED ON 11/09/2016 IN INSTRUMENT NO. 201626529.

### LEGAL DESCRIPTION

THE FOLLOWING DESCRIBED REAL ESTATE IN HENDRICKS COUNTY, STATE OF INDIANA.

LOT NUMBERED THIRTEEN (13) IN HARTFORD PARK FIRST SECTION, AN ADDITION TO THE TOWN OF BROWNSBURG, HENDRICKS COUNTY, INDIANA, AS PER PLAT THEREOF RECORDED MARCH 8, 1971, IN PLAT BOOK 7, PAGE 68, IN THE OFFICE OF THE RECORDER OF HENDRICKS COUNTY, INDIANA.

# Hendricks County, IN

## Property Record Card

[2024 Property Record Card \(PDF\)](#)  
[2023 Property Record Card \(PDF\)](#)

### Form 11

[32-07-15-258-009.000-016 \(PDF\)](#)

### Summary

**Parcel ID** 32-07-15-258-009.000-016  
**Bill ID** 014-215611-258009  
**Reference #** SEE LEGAL  
**Property Address** 302 Weston St  
 Brownsburg, IN, 46112  
**Brief Legal Description** Lot 13 Hartford Park Sec 10.28 AC 14.131-13  
 (Note: Not to be used on legal documents)  
**Class** RESIDENTIAL ONE FAMILY DWELLING ON A PLATTED LOT  
**Tax District** Town Of Brownsburg  
**Tax Rate Code** 79 - Advertised Tax Rate  
**Property Type** 82 - Residential  
**Mortgage Co** 15631475 - CORELOGIC  
**Last Change Date** 2/27/2024



### Owner

**Deeded Owner**  
 DIENER MICHAEL F  
 302 Weston Rd  
 Brownsburg, IN 46112

### Taxing District

**County:** Hendricks  
**Township:** LINCOLN TOWNSHIP  
**State District** 016 BROWNSBURG TOWN  
**Local District:** 014  
**School Corp:** BROWNSBURG COMMUNITY  
**Neighborhood:** 1451506 HARTFORD PARK SEC 1 & 2

### Site Description

**Topography:**  
**Public Utilities:**  
**Street or Road:**  
**Area Quality:** Static  
**Parcel Acreage:** 0.28

### Land

Land Type	Soil ID	Act Front.	Eff. Depth	Size	Rate	Adj. Rate	Ext. Value	Infl. %	Value
(F) FRONT LOT		0	107	113x107	\$277.00	\$283.00	\$31,979.00	0%	\$31,980.00

### Residential Dwellings

**Description** SINGLE-FAMILY RESIDENCE  
**Story Height** 1  
**Style**  
**Finished Area** 1414  
**# Fireplaces** 1  
**Heat Type** Central Warm Air  
**Air Cond** 1414  
**Bedrooms** 3  
**Living Rooms:** 0  
**Dining Rooms:** 0  
**Family Rooms:** 1  
**Finished Rooms:** 7  
**Full Baths** 2  
**Full Bath Fixtures** 6  
**Half Baths** 0  
**Half Bath Fixtures** 0  
**Kitchen Sinks** 1  
**Water Heaters** 1  
**Add Fixtures** 0

Floor	Construction	Base	Finish
1	Brick	1414	1414
C		1414	0

Features	Area
Patio, Concrete	240
Porch, Open Frame	147
Stoop, Masonry	9
Stoop, Masonry	9

**Improvements**

Descr	PC	Grade	Year Built	Eff Year	Cond	LCM	Size	Nbhd Factor	Mrkt Factor
SINGLE-FAMILY RESIDENCE	100	C	1972	1980	A	1.01	1414	1.68	0

**Transfers**

Date	New Owner	Doc ID	Book/Page	Sale Price
2/20/2024	DIENER, MICHAEL F	QCD		\$0.00
5/4/2022	DIENER, MARIA J & MICHAEL F	QCD		\$0.00
11/9/2016	DIENER, MARIA J	WD		\$136,000.00
11/13/2009	NEWINGHAM, JENNIFER M	0	0/0	\$177,500.00
8/15/2003	OHLSSON, LINNEA LYNN		452/1119	\$0.00
6/29/1999	LEMAY PATRICIA A			\$0.00

**Transfer History**

Date	Transfer From	Instrument	Book	Page	Doc Nbr
2/20/2024	DIENER MARIA J & MICHAEL F H/W				QCD
5/4/2022	DIENER MARIA J				QCD
11/9/2016	NEWINGHAM JENNIFER M				WD
11/13/2009	Ohlsson Linnea Lynn				wd
8/15/2003	Lemay Patricia A		452	1119	WD
6/29/1999	Unknown At Conversion	Conversion	0	0	

**Valuation**

Assessment Year	2024	2023	2022	2021	2020
Reason	ANNUAL ADJUSTMENT	ANNUAL ADJUSTMENT	ANNUAL ADJUSTMENT	ANNUAL ADJUSTMENT	ANNUAL ADJUSTMENT
As Of Date	4/10/2024	4/6/2023	4/7/2022	3/27/2021	4/1/2020
Land	\$32,000	\$29,000	\$27,700	\$27,700	\$27,700
Land Res (1)	\$32,000	\$29,000	\$27,700	\$27,700	\$27,700
Land Non Res (2)	\$0	\$0	\$0	\$0	\$0
Land Non Res (3)	\$0	\$0	\$0	\$0	\$0
Improvement	\$184,400	\$167,600	\$158,400	\$141,500	\$131,200
Imp Res (1)	\$184,400	\$167,600	\$158,400	\$141,500	\$131,200
Imp Non Res (2)	\$0	\$0	\$0	\$0	\$0
Imp Non Res (3)	\$0	\$0	\$0	\$0	\$0
<b>Total</b>	<b>\$216,400</b>	<b>\$196,600</b>	<b>\$186,100</b>	<b>\$169,200</b>	<b>\$158,900</b>
Total Res (1)	\$216,400	\$196,600	\$186,100	\$169,200	\$158,900
Total Non Res (2)	\$0	\$0	\$0	\$0	\$0
Total Non Res (3)	\$0	\$0	\$0	\$0	\$0

**Taxes**

[Click here to view Hendricks County tax data](#)

**Tax History**

	2022 Pay 2023	2021 Pay 2022	2020 Pay 2021	2019 Pay 2020
+ Spring Tax	\$930.50	\$845.20	\$757.80	\$684.72
+ Spring Penalty	\$0.00	\$0.00	\$0.00	\$0.00
+ Spring Annual	\$0.00	\$0.00	\$0.00	\$0.00
+ Fall Tax	\$930.50	\$845.20	\$757.80	\$684.72
+ Fall Penalty	\$0.00	\$0.00	\$0.00	\$0.00
+ Fall Annual	\$0.00	\$0.00	\$0.00	\$0.00
+ Delq NTS Tax	\$0.00	\$0.00	\$0.00	\$0.00
+ Delq NTS Pen	\$0.00	\$0.00	\$0.00	\$0.00
+ Delq TS Tax	\$0.00	\$0.00	\$0.00	\$0.00
+ Delq TS Pen	\$0.00	\$0.00	\$0.00	\$0.00
+ Other Assess	\$0.00	\$0.00	\$0.00	\$0.00
+ Advert Fee	\$0.00	\$0.00	\$0.00	\$0.00
+ Tax Sale Fee	\$0.00	\$0.00	\$0.00	\$0.00
+ NSF Fee	\$0.00	\$0.00	\$0.00	\$0.00
PTRC	\$0.00	\$0.00	\$0.00	\$0.00
HMST Credit	\$0.00	\$0.00	\$0.00	\$0.00
Circuit Breaker	\$76.79	\$0.00	\$0.00	\$0.00
Over 65 CB	\$0.00	\$0.00	\$0.00	\$0.00
<b>= Charges</b>	<b>\$1,861.00</b>	<b>\$1,690.40</b>	<b>\$1,515.60</b>	<b>\$1,369.44</b>
- Surplus Transfer	\$0.00	\$0.00	\$0.00	\$0.00
- Credits	(\$1,861.00)	(\$1,690.40)	(\$1,515.60)	(\$1,369.44)
<b>= Total Due</b>	<b>\$0.00</b>	<b>\$0.00</b>	<b>\$0.00</b>	<b>\$0.00</b>

**Photos**



Sketches

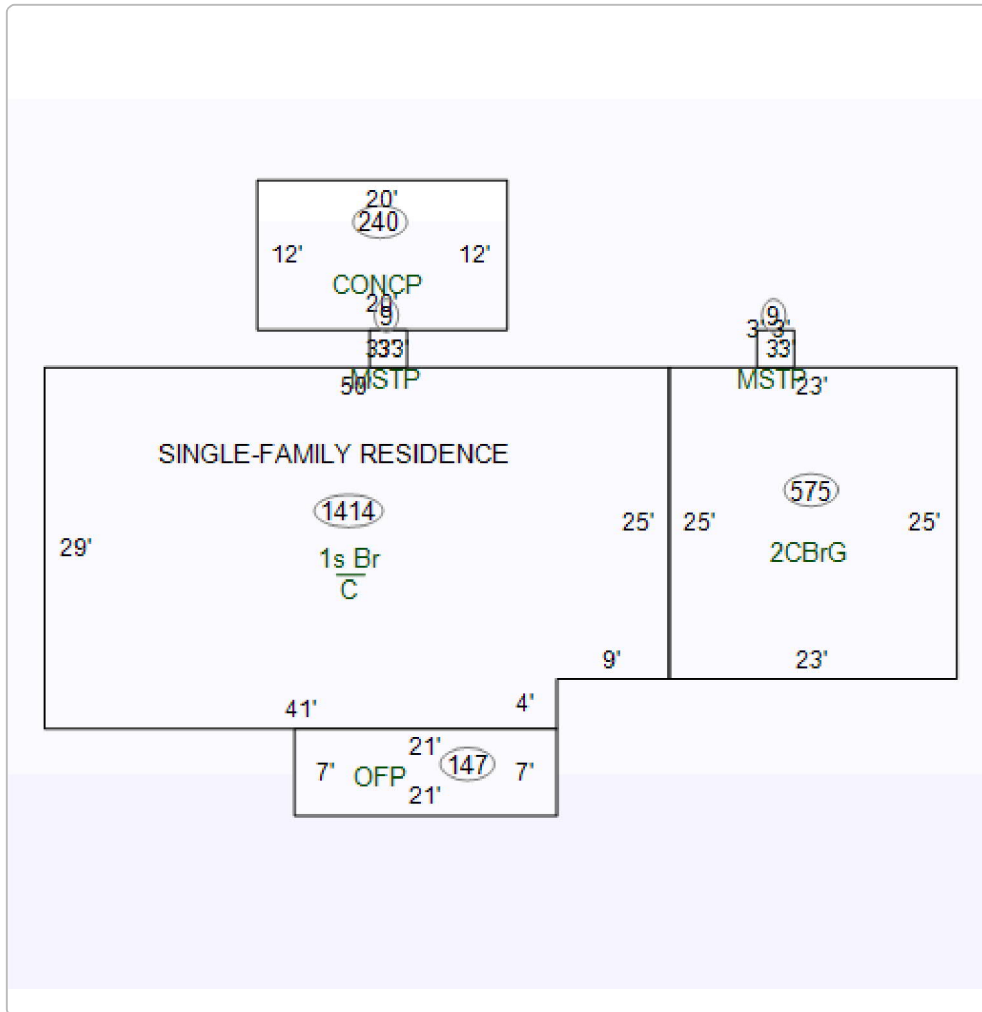

No data available for the following modules: Assessment Appeals Process, Commercial Buildings, Septic Permits.

The information in this web site represents current data from a working file which is updated continuously. Information is believed reliable, but its accuracy cannot be guaranteed. No warranty, expressed or implied, is provided for the data herein, or its use.  
[User Privacy Policy](#) | [GDPR Privacy Notice](#)  
 Last Data Upload: 30/09/2024, 08:05:26

Contact Us





DULY ENTERED  
FOR TAXATION

FEB 20 2024 TB

*Nancy L. Marsh*

AUDITOR HENDRICKS COUNTY

## QUITCLAIM DEED

THIS INDENTURE WITNESSETH, that **MARIA J. DIENER**, ("Grantor") of Hendricks County, in the State of Indiana, QUITCLAIMS to **MICHAEL F. DIENER**, ("Grantee") for no consideration, all of her interest in the following described real estate in Hendricks County, State of Indiana:

Lot Numbered Thirteen (13) in Hartford Park First Section, an addition to the Town of Brownsburg, Hendricks County, Indiana, as per plat thereof recorded March 8, 1971, in Plat Book 7, page 68, in the office of the Recorder of Hendricks County, Indiana.

More commonly known as 302 Weston Road, Brownsburg, Indiana 46112

Subject to all easements, rights of way, covenants and restrictions of record.

**NOTE: THIS TRANSFER IS FOR NO ECONOMIC CONSIDERATION AND  
SALES DISCLOSURE FORM 46021 (R11/12-11) IS NOT REQUIRED**

IN WITNESS WHEREOF, the Grantor has executed this Deed, this 16<sup>th</sup> day of February, 2024.

GRANTOR:

\_\_\_\_\_  
Maria J. Diener

REMOVE NAME 2/20/2024

**No Sales Disclosure Required**  
By: *Nicole Lawson*

STATE OF INDIANA            )  
  )  
COUNTY OF HENDRICKS    )

Before me, a Notary Public in and for said County and State, personally appeared Maria J. Diener, who acknowledged the execution of the foregoing, and who, having been duly sworn, stated that any representations therein contained are true.

Witness my hand and Notarial Seal this 16<sup>th</sup> day of February, 2024.



*Rachel L. Rudd*  
\_\_\_\_\_  
Rachel L. Rudd, Notary Public  
County of Residence: Marion  
My Commission Expires: December 19, 2031  
Commission No.: NP0753433

The undersigned affirms, under the penalties for perjury, that she has taken reasonable care to redact each Social Security number in this document, unless required by law:

JAMIE E. HARRELL

*This Instrument Prepared*    Jamie E. Harrell, Attorney #29946-32, HARRELL LAW LLC  
*By/Return To:*                7376 Business Center Drive, Suite B, Avon, Indiana 46123;  
  Phone: (317) 417-8638, Email: jamie@avonlaw.us;

*Send Tax Statements*         Michael F. Diener, 302 Weston Road, Brownsburg, Indiana 46112  
*To/Grantee's Address:*



## TRANSFER ON DEATH DEED

THIS INDENTURE WITNESSETH, that **MARIA J. DIENER** and **MICHAEL F. DIENER**, Husband and Wife ("Grantors") of Hendricks County, in the State of Indiana, QUITCLAIM to **MARIA J. DIENER** and **MICHAEL F. DIENER**, Husband and Wife, TRANSFER ON DEATH to **MICHAEL A. DIENER**, **JOSEPH F. DIENER**, and **ANN MARIE DIENER**, as Joint Tenants with Rights of Survivorship ("Grantees") for no consideration, the following described real estate in Hendricks County, State of Indiana:

Lot Numbered Thirteen (13) in Hartford Park First Section, an addition to the Town of Brownsburg, Hendricks County, Indiana, as per plat thereof recorded March 8, 1971, in Plat Book 7, page 68, in the office of the Recorder of Hendricks County, Indiana.

More commonly known as 302 Weston Road, Brownsburg, Indiana 46112  
Subject to all easements, rights of way, covenants and restrictions of record.

**NOTE: THIS TRANSFER IS FOR NO ECONOMIC CONSIDERATION AND  
SALES DISCLOSURE FORM 46021 (R11/12-11) IS NOT REQUIRED**

IN WITNESS WHEREOF, the Grantor has executed this Deed, this 3<sup>d</sup> day of  
MAY, 2022.

GRANTORS:

*Maria J. Diener*

\_\_\_\_\_  
Maria J. Diener

*Michael F. Diener*

\_\_\_\_\_  
Michael F. Diener





DULY ENTERED  
FOR TAXATION

May 04 2022 - JH

*Nancy A. Marsh*  
AUDITOR HENDRICKS COUNTY

202210751 D \$25.00  
05/04/2022 11:27:54AM 2 PGS  
Theresa Lynch  
Hendricks County Recorder IN  
Recorded as Presented



014-215611-258009

32-07-15-258-009.000-016

### QUITCLAIM DEED

THIS INDENTURE WITNESSETH, that **MARIA J. DIENER**, an adult, ("Grantor") of Hendricks County, in the State of Indiana, QUITCLAIMS to **MARIA J. DIENER** and **MICHAEL F. DIENER**, Husband and Wife ("Grantees") for no consideration, the following described real estate in Hendricks County, State of Indiana:

Lot Numbered Thirteen (13) in Hartford Park First Section, an addition to the Town of Brownsburg, Hendricks County, Indiana, as per plat thereof recorded March 8, 1971, in Plat Book 7, page 68, in the office of the Recorder of Hendricks County, Indiana.

More commonly known as 302 Weston Road, Brownsburg, Indiana 46112  
Subject to all easements, rights of way, covenants and restrictions of record.

**NOTE: THIS TRANSFER IS FOR NO ECONOMIC CONSIDERATION AND  
SALES DISCLOSURE FORM 46021 (R11/12-11) IS NOT REQUIRED**

IN WITNESS WHEREOF, the Grantor has executed this Deed, this 3rd day of May, 2022.

GRANTOR:

*Maria J. Diener*  
\_\_\_\_\_  
Maria J. Diener

05/04/2022  
No Sales Disclosure Required  
By: *Steve Johnson*

ADD SPOUSE



DULY ENTERED  
FOR TAXATION

NOV 9 2016

*Cinda Kottaw*  
AUDITOR HENDRICKS COUNTY

201626529 DEED \$18.00  
11/09/2016 02:59:59P 2 PGS  
Theresa D. Lynch  
Hendricks County Recorder IN  
Recorded as Presented



014-215611-258009

**WARRANTY DEED**

THIS INDENTURE WITNESSETH, that JENNIFER M. NEWINGHAM (Grantor), conveys and warrants to MARIA J. DIENER (Grantee) for the sum of One Dollar (\$1.00) and other valuable consideration, the receipt of which is hereby acknowledged, the following described real estate in Hendricks County, Indiana:

Lot Numbered Thirteen (13) in Hartford Park First Section, an addition to the Town of Brownsburg, Hendricks County, Indiana, as per plat thereof recorded March 8, 1971, in Plat Book 7, page 68, in the office of the Recorder of Hendricks County, Indiana.

Subject to all rights-of-way, easements and restrictions of record.  
Subject to all taxes now a lien and to become a lien thereon.

IN WITNESS WHEREOF, Grantor has executed this Deed this 31 day of October 2016

*Jennifer M. Newingham*  
\_\_\_\_\_  
Jennifer M. Newingham

STATE OF INDIANA            )  
  ) SS:  
COUNTY OF HENDRICKS    )

Before me, a Notary Public in and for said County and State, personally appeared JENNIFER M. NEWINGHAM, who acknowledged the execution of the foregoing instrument, and who, having been duly sworn, stated that any representations therein contained are true.

Witness my hand and Notarial Seal this 31 day of October, 2016

My Commission Expires:

10/14/21



*Rachel M. Parks*  
\_\_\_\_\_  
Signature of Notary Public

County of Residence  
Hamilton

Rachel M. Parks  
\_\_\_\_\_  
Printed Name of Notary Public

Tax mailing address ~~X~~ 302 Weston Rd. Brownsburg, In 46112

Grantee mailing address Same

I affirm, under the penalties for perjury, that I have taken reasonable care to redact each Social Security number in this document, unless required by law, Ben Comer.

This instrument was prepared by Ben Comer, 71 West Marion Street, P.O. Box 207, Danville, IN 46122, telephone: (317) 745-4300.

## Search Results for:

**NAME: DIENER MARIA (Super Search)**

**REGION: Hendricks County, IN**  
**DOCUMENTS VALIDATED THROUGH: 09/27/2024 3:18 PM**

Showing 5 results

Filter:

Document Details	County	Date	Type	Name	Legal
<a href="#">201626529</a>	Hendricks	11/09/2016	DEED : DEED	<b>DIENER, MARIA J</b> <a href="#">Search</a> <a href="#">Search</a> NEWINGHAM, JENNIFER M	<a href="#">Search</a> Lot 13 HARTFORD PARK SECTION 1
<a href="#">201626530</a>	Hendricks	11/09/2016	MORT : MORTGAGE	<b>DIENER, MARIA J</b> <a href="#">Search</a> <a href="#">Search</a> FAIRWAY INDEPENDENT MORTGAGE <a href="#">Search</a> MERS	<a href="#">Search</a> Lot 13 HARTFORD PARK SECTION 1
<a href="#">202210751</a>	Hendricks	05/04/2022	DEED : DEED	<b>DIENER, MARIA J</b> <a href="#">Search</a> <a href="#">Search</a> DIENER, MARIA J <a href="#">Search</a> DIENER, MICHAEL F	<a href="#">Search</a> Lot 13 HARTFORD PARK SECTION 1
<a href="#">202211025</a>	Hendricks	05/06/2022	MISC : TRANSFER ON DEATH DEED	<b>DIENER, ANN MARIE</b> <a href="#">Search</a> <a href="#">Search</a> DIENER, MARIA J <a href="#">Search</a> DIENER, MICHAEL F <a href="#">Search</a> DIENER, MARIA J <a href="#">see details for more</a>	<a href="#">Search</a> Lot 13 HARTFORD PARK SECTION 1
<a href="#">202402934</a>	Hendricks	02/20/2024	DEED : DEED	<b>DIENER, MARIA J</b> <a href="#">Search</a> <a href="#">Search</a> DIENER, MICHAEL F	<a href="#">Search</a> Lot 13 HARTFORD PARK SECTION 1

The data or information provided is based on information obtained from Indiana Courts, Clerks, Recorders, and Department of Revenue, and is not to be considered or used as an official record. Doxpop, LLC, the Division of State Court Administration, the Indiana Courts and Clerks of Court, the Indiana Recorders, and the Indiana Department of Revenue: 1) Do not warrant that the information is accurate or complete; 2) Make no representations regarding the identity of any persons whose names appear in the information; and 3) Disclaim any liability for any damages resulting from the release or use of the information. The user should verify the information by personally consulting the official record maintained by the court, clerk, recorder or Department of Revenue.

Copyright © 2002-2024 Doxpop, Ilc. All Rights Reserved

# Search Results for:

NAME: **DIENER MICHAEL (Super Search)**



REGION: **Hendricks County, IN**

DOCUMENTS VALIDATED THROUGH: **09/27/2024 3:18 PM**

Showing 3 results

Filter:

Document Details	County	Date	Type	Name	Legal
<a href="#">202210751</a>	Hendricks	05/04/2022	DEED : DEED	<b>DIENER, MICHAEL F</b> <a href="#">Search</a> <a href="#">Search</a> DIENER, MARIA J <a href="#">Search</a> DIENER, MARIA J	<a href="#">Search</a> Lot 13 HARTFORD PARK SECTION 1
<a href="#">202211025</a>	Hendricks	05/06/2022	MISC : TRANSFER ON DEATH DEED	<b>DIENER, MICHAEL A</b> <a href="#">Search</a> <a href="#">Search</a> DIENER, MARIA J <a href="#">Search</a> DIENER, MICHAEL F <a href="#">Search</a> DIENER, MARIA J <a href="#">see details for more</a>	<a href="#">Search</a> Lot 13 HARTFORD PARK SECTION 1
<a href="#">202402934</a>	Hendricks	02/20/2024	DEED : DEED	<b>DIENER, MICHAEL F</b> <a href="#">Search</a> <a href="#">Search</a> DIENER, MARIA J	<a href="#">Search</a> Lot 13 HARTFORD PARK SECTION 1

The data or information provided is based on information obtained from Indiana Courts, Clerks, Recorders, and Department of Revenue, and is not to be considered or used as an official record. Doxpop, LLC, the Division of State Court Administration, the Indiana Courts and Clerks of Court, the Indiana Recorders, and the Indiana Department of Revenue: 1) Do not warrant that the information is accurate or complete; 2) Make no representations regarding the identity of any persons whose names appear in the information; and 3) Disclaim any liability for any damages resulting from the release or use of the information. The user should verify the information by personally consulting the official record maintained by the court, clerk, recorder or Department of Revenue.

Copyright © 2002-2024 Doxpop, LLC. All Rights Reserved