

Key: 3287

Town of CARVER - Fiscal Year 2024

12/3/2023 6:06 pm SEQ #: 3,216

LEGAL LAND

CURRENT OWNER				PARCEL ID				LOCATION			
CHEESMAN STEPHEN S CHEESMAN LYNNE M 11 WHITE PINE LANE CARVER, MA 02330				68-A-13-R				11 WHITE PINE LN			
TRANSFER HISTORY				DOS	T	SALE PRICE	BK-PG (Cert)				
CHEESMAN STEPHEN S				09/30/2002	QS	256,000	22995-191				
LACAVA RUSSELL T				06/25/1990	QS	125,000	9819-057				
ANDERSON				01/01/1972	X	1	3812-611				

CLASS	CLASS%	DESCRIPTION			BN ID	BN	CARD	
1010	100	SINGLE FAMILY				1	1 of 1	
PMT NO	PMT DT	TY	DESC	AMOUNT	INSP	BY	1st	%
2014-318	09/23/2014	50	PERMIT VISIT	2,500	01/07/2016	HW	100	100
		50	PERMIT VISIT		08/18/2015	HW	100	100
		55	LEFT NOTICE		10/21/2014		100	100
		20	SHED		09/25/2020	TCK	100	100
		56	LEFT 2ND NOT		08/28/2008	MA	100	100

LEGAL LAND

CD	T	AC/SF/UN	Ngh	INFL1	INFL2	ADJ BASE	SAF	INFL3	Lpi	VC	CREDIT AMT	ADJ VALUE
100	S	44,866	NCR 1.00	1	1.00	110,300	1.25	1	1.00	NCR 1.00		142,320

TOTAL	1.030 Acres	ZONING	RA	FRNT	150	ASSESSED	CURRENT	PREVIOUS
Ngh	NORTH CARVER	NOTE				LAND	142,300	142,300
INFL1	NO ADJUST.		BUILDING	269,700	247,500			
INFL2	NO ADJUST.		DETACHED	30,900	29,600			
						OTHER	0	0
						<b>TOTAL</b>	<b>442,900</b>	<b>419,400</b>

DETACHED

TY	QUAL	COND	DIM/NOTE	YB	UNITS	ADJ PRICE	RCNLD	PHOTO
CAB	A	1.00	40 0.60 12X12	2006	144	43.20	3,700	
IPV	A	1.00	40 0.60 16X32	1974	512	29.90	9,200	
HTB	A	1.00	00 1.00 ON WDK	2007	1	4,845.40	4,800	
PTD	A	1.00	00 1.00 10X10	2005	100	15.60	1,600	
WDK	A	1.00	00 1.00 16X17	2015	272	33.03	9,000	
SHF	A	1.00	10 0.90 14X14	2016	196	14.90	2,600	

BUILDING

BUILDING	CD	ADJ	DESC	MEASURE	6/30/2016	HW
MODEL	1		RESIDENTIAL	LIST		
STYLE	2	0.90	RAISED RANCH [100%]	REVIEW	10/1/2020	EMZ
QUALITY	C	1.00	AVERAGE [100%]			
FRAME	1	1.00	WOOD FRAME [100%]			

BUILDING

YEAR BLT	1974	SIZE ADJ	1.340	ELEMENT	CD	DESCRIPTION	ADJ	S	BAT	T	DESCRIPTION	UNITS	YB	ADJ PRICE	RCN
NET AREA	1.020	DETAIL ADJ	0.900	FOUNDATION	4	BSMT WALL & FL	1.00	+	BAS	L	BAS 1ST FL AREA	1,020	1974	210.81	215,025
\$NLA(RCN)	\$367	OVERALL	1.000	EXT. COVER	4	VINYL	1.00	+	WDK	N	ATT WOOD DECK	303		41.65	12,621
				ROOF SHAPE	1	GABLE	1.00	C	LLU	N	LOWER LEVEL UNF	469		91.54	42,930
				ROOF COVER	1	ASPHALT SHINGLE	1.00	C	LLF	N	LOWER LEVEL FIN	469		168.48	79,016
STORIES	1		1.00	FLOOR COVER	3	W/W CARPET	1.00		FPL	O	FPL, FIREPLACE	1		9,188.00	9,188
ROOMS	5		1.00	INT. FINISH	2	DRYWALL	1.00								
BEDROOMS	3		1.00	HEATING/COOLING	1	FORCED AIR	1.00								
BATHROOMS	1		1.00	FUEL SOURCE	2	GAS	1.00								
TOT FIXTURES	3	\$6,750		KITHCHEN RATING	1	AVERAGE	0.00								
HALFBATHS	0		1.00	BATH RATING	1	AVERAGE	0.00								
UNITS	1		1.00	PARTITION	1	TYPICAL	1.00								
# KITCHENS	1	\$9,000													

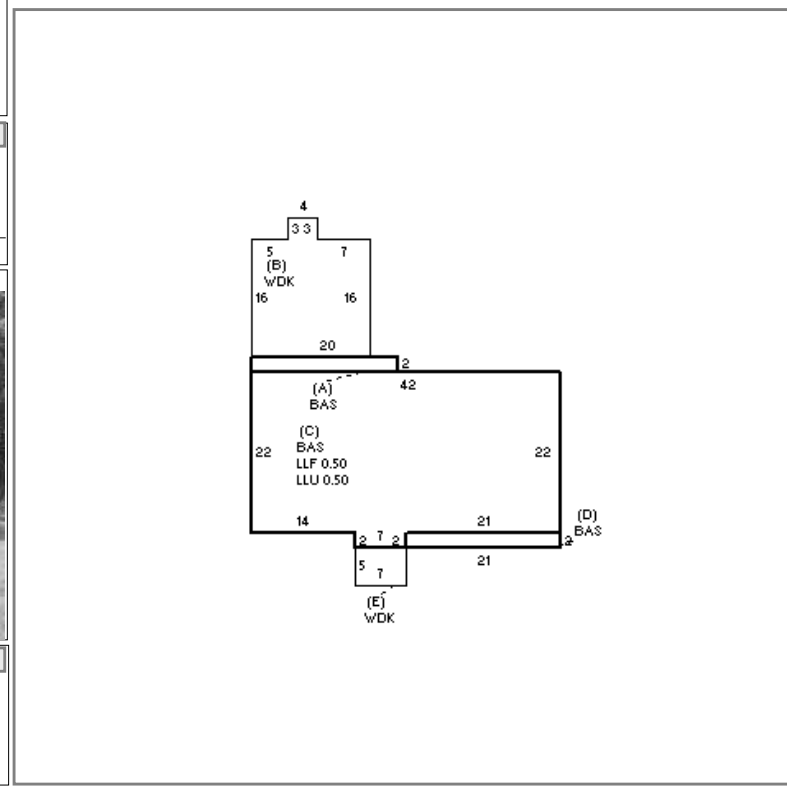

BLDG COMMENTS

TOTAL RCN	374.530
CONDITION ELEM	CD
EXTERIOR	A
INTERIOR	A
KITCHEN	A
BATHS	A
HEAT	A
ELECT	A
EFF.YR/AGE	1985 / 37
COND	28 28 %
FUNC	0
ECON	0
DEPR	28 % GD 72
RCNLD	\$269,700