

## 8 GREENLAWN RD

**Location** 8 GREENLAWN RD

**Map/Lot** 021/ 080/ 00/ /

**Acct#** 02108000

**Owner** FENSORE RALPH R + CARISSA LYNN

**Assessment** \$205,800

**Appraisal** \$293,900

**PID** 8963

**Building Count** 1

**Survey** 487 18

**Affordable**

### Current Value

Appraisal			
Valuation Year	Improvements	Land	Total
2019	\$150,800	\$143,100	\$293,900
Assessment			
Valuation Year	Improvements	Land	Total
2019	\$105,600	\$100,200	\$205,800

### Owner of Record

**Owner** FENSORE RALPH R + CARISSA LYNN

**Sale Price** \$0

**Co-Owner**

**Certificate**

**Address** 8 GREENLAWN RD  
MONROE, CT 06468

**Book & Page** 2020/0166

**Sale Date** 11/13/2018

**Instrument**

### Ownership History

Ownership History					
Owner	Sale Price	Certificate	Book & Page	Instrument	Sale Date
FENSORE RALPH R + CARISSA LYNN	\$0		2020/0166		11/13/2018
FENSORE RALPH R	\$282,500		1956/0051	0	04/03/2017
GUERRA ERIK	\$0	1	1555/0195		07/02/2008
BANK OF NEW YORK - TRSTEES *(NOTES)	\$0	2	1529/0314		01/10/2008
CANNON DAVID O + PAULA M	\$0	4	1187/0115		07/30/2003

### Building Information

#### Building 1 : Section 1

**Year Built:** 1959

**Living Area:** 1,460

Building Attributes	
Field	Description

Style:	Split Level
Model	Residential
Grade:	C+
Stories:	1
Occupancy	1
Exterior Wall 1	Frame
Exterior Wall 2	
Roof Structure:	Gable/Hip
Roof Cover	Asph Shngl
Interior Wall 1	Drywall
Interior Wall 2	
Interior Flr 1	Hardwood
Interior Flr 2	
Heat Fuel	Gas
Heat Type:	Hot Water
AC Type:	Central AC
Total Bedrooms:	3
Total Bthrms:	2
Total Half Baths:	0
Total Xtra Fixtrs:	0
Total Rooms:	8
Bath Style:	Modern
Kitchen Style:	Modern
Fireplace(s)	0
Cndtn	
Wdstv Flues	
Basement Gar.	0
Num Park	
Fireplaces	
Attic	None
CNS_USRFLD_102	Half
Accessory Apt	0
Fndtn Cndtn	
Basement	

## Building Photo



(<https://images.vgsi.com/photos/MonroeCTPhotos/A00\00\92\39.jpg>)

## Building Layout

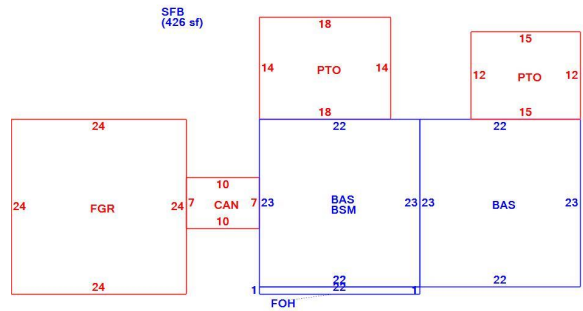

(ParcelSketch.ashx?pid=8963&bid=8963)

Building Sub-Areas (sq ft)			Legend	
Code	Description	Gross Area	Living Area	
BAS	First Floor	1,012	1,012	
SFB	Basement Living Area	426	426	
FOH	Frame Overhang	22	22	
BSM	Basement	506	0	
CAN	Canopy	70	0	
FGR	Garage	576	0	
PTO	Patio	432	0	
		3,044	1,460	

## Extra Features

Extra Features		Legend
No Data for Extra Features		

## Parcel Information

<b>Use Code</b>	101
<b>Description</b>	Single Family
<b>Deeded Acres</b>	1.01

**Land**

<b>Land Use</b>		<b>Land Line Valuation</b>	
<b>Use Code</b>	101	<b>Size (Acres)</b>	1.01
<b>Description</b>	Single Family	<b>Appraised Value</b>	\$143,100
<b>Zone</b>	RF1		
<b>Neighborhood</b>	Monroe		
<b>Alt Land Approved Category</b>	No		

**Outbuildings**

<b>Outbuildings</b>	<b>Legend</b>
No Data for Outbuildings	

**Valuation History**

<b>Appraisal</b>			
<b>Valuation Year</b>	<b>Improvements</b>	<b>Land</b>	<b>Total</b>
2020	\$150,800	\$143,100	\$293,900

<b>Assessment</b>			
<b>Valuation Year</b>	<b>Improvements</b>	<b>Land</b>	<b>Total</b>
2020	\$105,600	\$100,200	\$205,800