

## 22 FLUME RD

**Location** 22 FLUME RD

**Mblu** 169/ 36/ / /

**Assessment** \$788,900

**PID** 9082

**Building Count** 1

### Current Value

Assessment			
Valuation Year	Improvements	Land	Total
2023	\$514,700	\$274,200	\$788,900

### Ownership History

Ownership History			
Owner	Sale Price	Book & Page	Sale Date
SHATFORD DANIEL P	\$170,000	15268/0225	11/24/1998
SHATFORD PATRICIA M	\$1	5277/0768	06/01/1965

### Building Information

#### Building 1 : Section 1

**Year Built:** 1920

**Living Area:** 2,623

**Building Percent Good:** 80

Building Attributes	
Field	Description
Style:	Colonial
Model	Residential
Grade:	Average +10
Stories:	1 3/4 Stories
Occupancy	1
Exterior Wall 1	Shingle
Exterior Wall 2	
Roof Structure:	Gable/Hip
Roof Cover	Asph/F GlS/Cmp
Interior Wall 1	Plywood Panel

### Building Photo



([https://images.vgsi.com/photos2/GloucesterMAPhotos//0049\DSCN5522\\_](https://images.vgsi.com/photos2/GloucesterMAPhotos//0049\DSCN5522_)

Interior Wall 2	
Interior Flr 1	Hardwood
Interior Flr 2	
Heat Fuel	Oil
Heat Type:	Hot Water
AC Type:	None
Total Bedrooms:	4 Bedrooms
Total Bthrms:	2
Total Half Baths:	0
Total Xtra Fixtrs:	
Total Rooms:	
Bath Style:	
Kitchen Style:	
Num Kitchens	01
Cndtn	
Num Park	
Fireplaces	
Fndtn Cndtn	
Basement	

### Building Layout

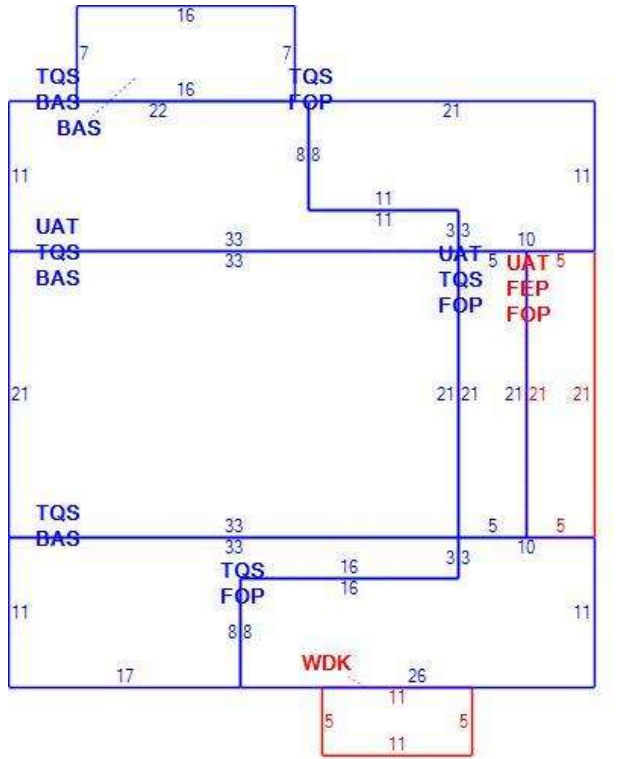

(ParcelSketch.ashx?pid=9082&bid=9257)

Building Sub-Areas (sq ft)			Legend
Code	Description	Gross Area	Living Area
BAS	First Floor	1,315	1,315
TQS	Three Quarter Story	1,744	1,308
FEP	Porch, Enclosed, Finished	105	0
FOP	Porch, Open, Finished	646	0
UAT	Attic, Unfinished	903	0
WDK	Deck, Wood	55	0
		4,768	2,623

### Extra Features

Extra Features			Legend
Code	Description	Size	Bldg #
FPL3	2 STORY CHIM	1.00 UNITS	1

### Land

#### Land Use

Use Code	1010
Description	SING FAM
Zone	R-20

#### Land Line Valuation

Size (Acres)	0.23
Depth	0
Assessed Value	\$274,200

**Outbuildings**

Outbuildings	<u>Legend</u>
No Data for Outbuildings	

**Valuation History**

Assessment			
Valuation Year	Improvements	Land	Total
2022	\$450,800	\$238,500	\$689,300
2021	\$410,400	\$216,800	\$627,200
2020	\$415,600	\$204,500	\$620,100